

BODY SPECIFICATIONS

Body Capacity	11yd ³	13yd ³
A. Body Length	191"	209"
B. Height Of Body Above Chassis	74"	74"
C. Body Width	94"	94"
D. Hopper Opening Width	74"	74"
E. Loading Sill Below Chassis Frame	0"	0"
F. Hopper Opening Height	58"	58"
F. Height Of Tailgate Above Chassis Frame (Tailgate Raised)	191"	191"
G. Length Of Body (Tailgate Raised)	221"	239"
CA. Cab To Axle Minimum	108"	126"
CF. Minimum Usable Cab To End Of Frame	140"	158"
Hopper Capacity	1.75yd ³	1.75yd ³
Dynamic Hopper Capacity (yd ³ /minute)	7yd ³	7yd ³
Body Weight	8,400 LBS.	8,750 LBS.

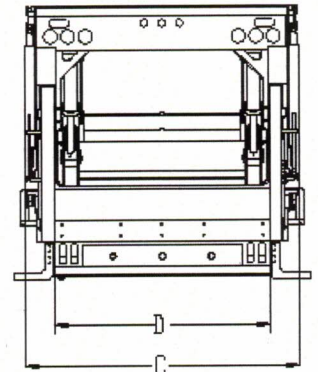
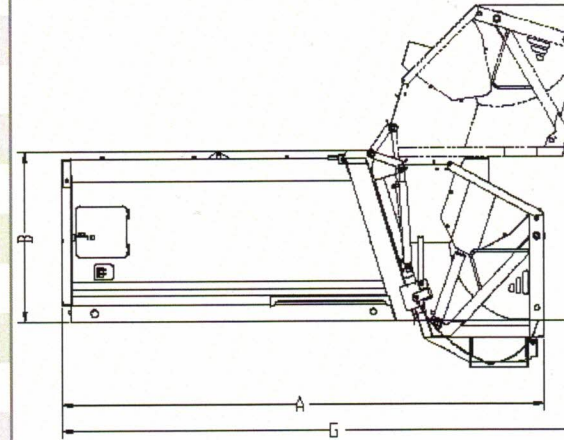

MINIMUM CHASSIS REQUIREMENTS

Minimum GVWR	29,000 LBS.*	33,000 LBS.
Front Axle	10,000 LBS.	10,000 LBS.
Rear Axle	19,000 LBS.	23,000 LBS.
Required Frame Height	38" - 40"	38" - 40"
Chassis Frame Height	36" - 39"	36" - 39" 210"

*11yd Quantum can be configured for under CDL with a 26,000 LBS. min. GVWR (10,000 LBS. front axle & 16,000 LBS. rear axle). However, this configuration reduces the allowed LBS./yd³ by 30% to remain at or below min. GVWR.

Body Construction

- Body Sides: 11 Gauge GR50
- Body Roof: 11 Gauge GR50
- Body Floor: 11 Gauge GR50
- Ejection Panel: 11 Gauge GR50
- Sweep Face: 3/16 GR100
- Tailgate Side Wall: 11 Gauge GR50 Upper, 7 Gauge GR50 Lower
- Tailgate Floor: 3/16 AR400

Features

- High Strength Curved Shell Body
- Patented Packing Mechanism
- Rear Fenders Standard
- Curved Floor Provides Liquid Sump
- Low Body Height
- Easy to Maintain
- Pack Cycle Time of 15 Seconds

Hydraulics

- Oil Reservoir: 25 Gal. (94.6 Liters)
- Oil Flow w/ Standard Pump: 25 GPM
- Operating Pressure: 3,000 PSI
- Engine RPM: 1,300 RPM
- Hose Burst Ratio: 4 to 1
- Return Filter: 10 Micron
- Pack Cylinders: 4.0"
- Sweep Cylinders: 4.0"
- Eject Cylinders
 - 11yd³: 4.5", 2 Stage Telescopic
 - 13yd³: 5.0", 3 Stage Telescopic
- Tailgate Lift: 3"

Optional Features

- Container Roll Bar with Lip-and-Latch
- Container Lip-And-Latch with LBS. Drum Winch
- Single & Dual Tipper(s)
- Cart Tipper Tap-In-Kits
- Work Lights
- Strobe Lights
- Broom and Shovel Holder
- Rear View Color Camera Sys

